



## EQ2500 PARALLEL (EQ) RELAY

### FOR TYPE A 25, 40 & 50 AMP DELCO-REMY GENERATOR SYSTEMS

#### Features:

- Precise EQ Pull-in & Drop-out Voltages
- Electronic EQ Voltage Sensing
- Counter-EMF Diode on EQ Relay
- Applicable to Old & New Technologies

#### Benefits:

- \* Increase Relay Life, reduced arcing
- \* Makes EQ Pull-in & Drop-out Voltages precise
- \* Increase Relay Life, reduced arcing
- \* Works with Electronics GCU & Vibrating Point Regulator

**EQ Pull-in Voltage: 24.7V  $\pm$  0.5V; Drop-Out Voltage:  $< \pm$  0.1V from Pull-in Voltage. Max Current: 5A.**

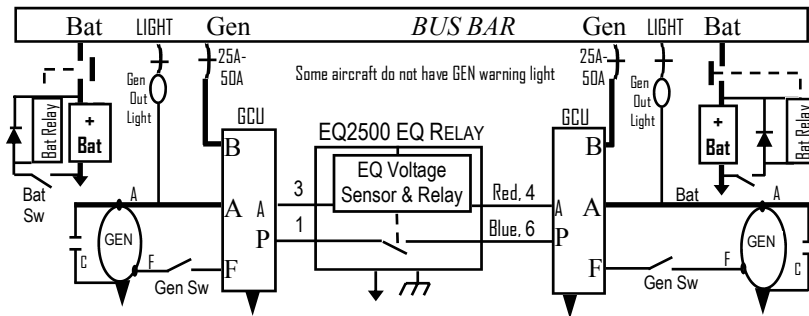

The EQ2500 Equalizer (EQ) or Parallel Relay is a normally open electronic switch used on twin engine aircraft to share electrical loads equally between two or more generator systems. It monitors the armature voltages of two generators. When the output of the two generators reach a predetermined “build-up” or “parallel” voltage, the EQ relay is closed tying the two generator systems together. When the output of one generator exceeds the other, current flows from it through the Regulator/GCU in a direction that causes the other generator’s output to increase. This action is repeated until both outputs match.

If the armature voltage of either generator drops below the parallel voltage, the EQ relay will open, isolating the generators.

#### **The Generator Electrical Charging System (GECS)**

The Generator provides power used in charging the battery and running other electrical systems in the aircraft. The current flowing through the field of a Generator controls its output current. The **Generator Control Units (GCU)** have **Voltage Regulation with Generator Build-up, Current Limiter, and Reverse Current Protection.**

Part No	Volt	Amp	Replaces Delco-Remy P/N
EQ2500	24	5	1116902

*The GECS continued ...*

The **Generator Build-up** function allows the rotating generator to build-up its output from a low residual voltage to the system’s voltage regulation point.

The **Voltage Regulator (VR)** controls the Generator’s field to keep the aircraft electrical system voltage at a specific level. This controller has a “Type A” regulator which excites the field of the generator by providing controlled ground to one side of the field (F), with the other side internally connected to the armature.

The **Current Limiter (CL)** controls the maximum output current the generator can produce. It turns off the field excitation when the output current exceeds the CL set point (determined by the generator’s current rating). It allows normal field excitation when the generator’s output is below the GCU CL set point.

The **Reverse Current (RC) Protection** circuit blocks the battery current from going back to the generator. It allows current to flow only from the generator to the battery and system.



## EQ2500

### HOW THE SYSTEM WORKS

The Generator provides power used in charging the battery and running other electrical systems in the aircraft. The current flowing through the field of a Generator controls its output current. The **Generator Control Units (GCU)** have **Voltage Regulation with Generator Build-up, Current Limiter, Reverse Current Protection and Paralleling (EQ, Load sharing)**.

The **Generator Build-up** (or automatic field flashing) function allows the rotating generator to build-up its output from a low residual voltage to the voltage regulation point. Closing the Gen (Field) switch when the generator is rotating causes current to flow from its armature through the field to ground in the GCU. This current flow rapidly increases the generator output voltage from a few volts until the build-up cut off occurs and the voltage regulator takes over the control of the generator. At the build-up cut off point, the GB switch inside the GCU opens and stays open until the Gen Field switch and Bat switches are reset. This prevents generator cycling problems seen in other voltage regulators.

The **Voltage Regulator (VR)** controls the Generator's field to keep the aircraft electrical system voltage at a specific level. This controller has a "Type A" regulator which excites the field of the generator by controlling the grounding of one side of the field (F), while the other side is internally connected to the armature. The VR electronics switch turns the field current on/off so fast (several times a second) that the output voltage of the generator stays at the VR set point. As long as the generator's output voltage is less than the VR set point the switch is closed, current flows, and the Generator's output increases. When the generator's output voltage exceeds the VR set point, the switch opens, current flow stops, and the generator's output decreases. The Current Limiter and Parallel functions affects voltage regulation.

The **Current Limiter (CL)** controls the maximum output current the generator can produce. It turns off the field excitation when the output current exceeds the CL set point (determined by the generator's current rating). It allows normal field excitation when the generator output is below the GCU CL set point.

The **Reverse Current (RC) Protection** circuit blocks the battery current from going back to the generator. It allows current to flow only from the generator to the

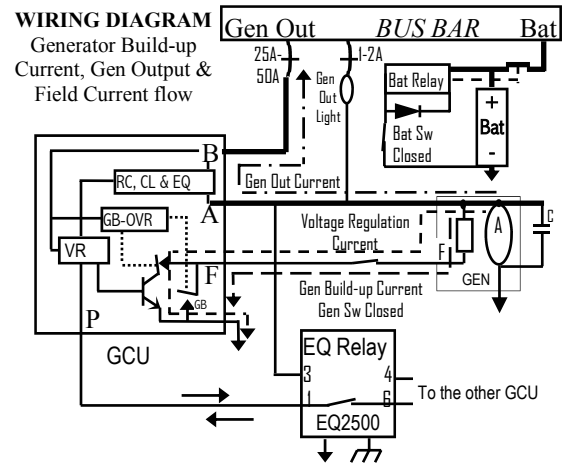

The **Equalizer (EQ) or Parallel Relay is a normally open electronic switch** used on twin engine aircraft to share electrical loads equally between two or more generator systems. It monitors the armature voltages of two generators. When the output of the two generators reach a predetermined "build-up" or "parallel" voltage, the EQ relay closes, tying the two generator systems together. When the output of one generator exceeds the other, current flows from it through the GCU in a direction that causes the other generator's output to increase. This action is repeated until both outputs match. If either generator's armature voltage drops below the parallel voltage, the EQ relay will open, isolating the generators.

**Protection against GCU induced OV fault.** The GCU's design will cause the field current path (between the field and ground) to open and the VR to switch off if the field control device becomes internally ground shorted. This means that the GCU will not induce Over-Voltage (OV) problem into the system. The GCU does not protect the system against externally induced OV faults. The ZEFTRONICS G2XXPN GCUs provide this prescribed OV protection.

**Caution:** Check the condition of the battery. A depleted /discharged battery will draw excessive current and could trigger the Current Limiter function to turn off the GCU's voltage regulator. Connecting power to the GEN field to excite it will reverse its polarity. **DO NOT connect power to the field of the generator.** Follow the Field flashing procedure outline in the trouble-shooting section of this document.



# EQ2500

## TROUBLE-SHOOTING THE SYSTEM

### CHECKING THE RESIDUAL VOLTAGE AND POLARITY OF THE GENERATOR

Connect a voltmeter between the generator's ARM and ground. At 1300 RPM, the generator's output or residual voltage should be positive (greater than +2.2V).

Residual Voltage \_\_\_\_\_ V @ \_\_\_\_\_ RPM

A negative voltage reading indicates a generator that has a reverse polarity. **Do not connect the GCU to a generator with reversed polarity. Turn off the engine and Polarize the generator by flashing the field.**

### HOW TO FLASH THE GENERATOR'S FIELD:

1. With the engine off, disconnect the Generator Controller (GCU) / Regulator
2. Ground the Field wire removed from the GCU and turn on the GEN FLD switch

At the GCU: Touch the battery wire to the generator's armature wire 5 times for 3-5 seconds. Caution: Take safety precaution to prevent being hurt by electrical sparks generated by touching the two wires.

3. Connect a voltmeter between the generator's ARM and ground. At 1300 RPM, the generator output or residual voltage should be  $>+2.2V$ .  
ARM Voltage \_\_\_\_\_ V @ \_\_\_\_\_ RPM

### Refer to the Trouble-Shooting Diagram

1. Disconnect the GCU & EQ Relay from the system.
2. On the wires removed from the GCU & EQ relay, with the field switch open measure the resistances at the points indicated by  $\Omega$ . Record the values.

At the Generator Measured	Typical Value
ARM to GND _____ $\Omega$	0.1 $\Omega$ (Max)
FLD to ARM _____ $\Omega$	14-18 $\Omega$
FLD to GND _____ $\Omega$	14-18 $\Omega$

At the Zeftronics GCU Measured.	Typical Value
ARM to BAT _____ $\Omega$	$>250\Omega$
ARM to GND _____ $\Omega$	$>2K\Omega$
FLD to ARM _____ $\Omega$	$>2K\Omega$
FLD to GND _____ $\Omega$	1 $\Omega$ (Max)
BUS to B _____ $\Omega$	0.1 $\Omega$ (Max)

At the EQ Relay Measured	Typical Value
Terminal 1 to 6 _____ $\Omega$	$>10K\Omega$

If all the measurements are as specified, connect the GCU to the system and retest the Generator Electrical Charging System (GECS).

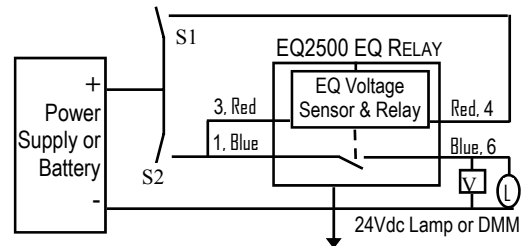
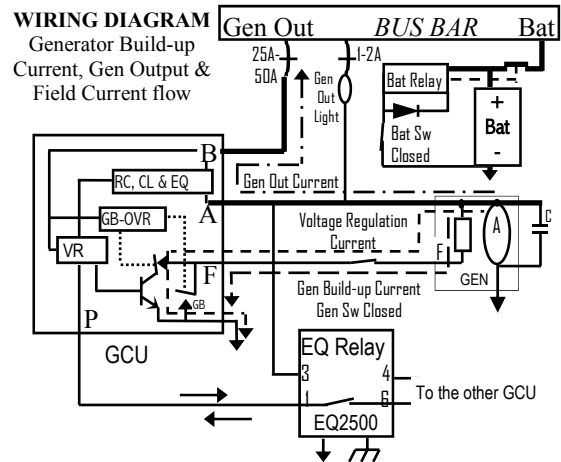

Figure EQT: Test Set up for EQ Relay

### No Load Sharing or System not Paralleling

Remove the Parallel Relay from the aircraft and connect it as shown to a power supply or battery that can provide 25.2 to 26.5V, 2A DC.

1. Connect the EQ Relay to S1, S2, L or DMM and the power supply according to figure EQT.
2. Set the power supply or battery to 25.2 to 26.5V DC.
3. Close S1, the L Light should be off, no voltage on V.
4. Close S2, the L Light should be on, 25.2 to 26.5V on V. *If L is off and no voltage on V, the EQ Relay may be damaged. Return it to ZEFTRONICS or a ZEFTRONICS approved repair station. If step 4 operates as specified, perform step 5.*
5. Open S1 or S2: observe that L goes off and V is 0 V.
6. *Optional:* with L on, reduce the Battery or power supply voltage to 24V. Observe that L goes off before 24V.
7. If the EQ Relay passes all the tests, check the regulator or GCU for problems. Also check the condition of the wires, connections, and generators.



# Installation & Continued Airworthiness Maintenance Instructions

## EQ RELAY & GCU/REGULATOR: TROUBLE-SHOOTING THE SYSTEM

### CAUTION:

Grounding the field to see if the generator produces current is not a good indication that it is working properly. Doing so can lead to excessive system voltage, which may damage batteries, radios and GCU. This practice will not always identify a defective voltage regulator because it can and does often hide field or armature defects.

### PRE-INSTALLATION TESTS.

#### BEFORE INSTALLING THIS UNIT, PERFORM TESTS:

1. Read the documents that came with the unit.
2. Disconnect the current voltage regulator or GCU.
3. Charge Gell-cell batteries before installing the unit.
4. Turn on the Gen Field switch
5. Check the Generator Residual Voltage & Polarity:
  - a. Connect a voltmeter between the Generator's ARM and ground.
  - b. At 1200 RPM, the generator's output should be positive (>1.6V). If it is negative, the generator has a reverse polarity. Turn off the engine, and flash the field. Do NOT connect the GCU to the generator.
6. Measure and record the following resistances separately, at the generator & the wires to the GCU, list them below.
 

	At Generator	At GCU Wire
a. Gen Arm to Case-Ground	_____Ω	_____Ω
b. Gen Fld to Case-Ground	_____Ω	_____Ω
c. Gen Fld to ARM	_____Ω	_____Ω
d. Bus-GCU BAT	_____Ω	_____Ω
7. If the measured values are out of the specified ranges (listed on page 3), check the wiring, circuit breakers, switches, connection or generator .
8. If the measured values are as specified, install the unit and perform the post installation tests.

OUR GOAL IS TO HELP YOUR SYSTEM OPERATE BETTER AND HELP YOU BETTER UNDERSTAND ITS OPERATION.

### INSTALLATION INSTRUCTION & TESTS.

1. Mount the EQ2500 in the place of the removed Parallel Relay.
2. Connect the two blue wires to #1 and 6 of the old unit. Connect the two Red wires to #3 and 4 of the old unit. The order in which the Red and blue wires are connected does not matter, as long as, the blue ones go to the Regulator/GCU P terminals and the Red wires go to the Regulator/GCU ARM terminals.
3. Connect the ARM, FLD, BAT and P to the GCU.
4. With the engine off, turn on the Bat & Gen Field switches; on the GCU measure & record the following voltage:

	24V Values	Typical Values
A. BAT	_____V	23 – 26V
B. FLD	_____V	0 – 2.5V
C. ARM	_____V	0 – 0.2V
D. P (EQ)	_____V	_____V+

+Depends on the battery voltage

4. If the measured values are as specified, connect the unit and perform the post installation tests.

### POST-INSTALLATION CHECK AND TESTS

1. With the BAT and FLD switches on and engine off, check the connections and polarities of all installed GECS components.
2. With the BAT and FLD switches on and engine running, the generator should come on line at 1100 - 1400 RPM: the bus voltage should be 27.9 to 28.5V. At 1800 RPM the bus voltage should remain at 27.9V to 28.5V until about 5 Amps below the generator's current rating

For tech help, tech cards and system design assistance,

call: **903-758-6661.**

Fax: 903-236-9766

Email: [Tech@zeftronics.com](mailto:Tech@zeftronics.com)

### INSTRUCTIONS FOR

### CONTINUED AIRWORTHINESS MAINTENANCE

This device is not field repairable or serviceable. For all service, repair or overhaul needs, return it to ZEFTRONICS or a ZEFTRONICS approved repair station. For all periodic inspection and test requirement, use the pre and post installation procedure listed above.

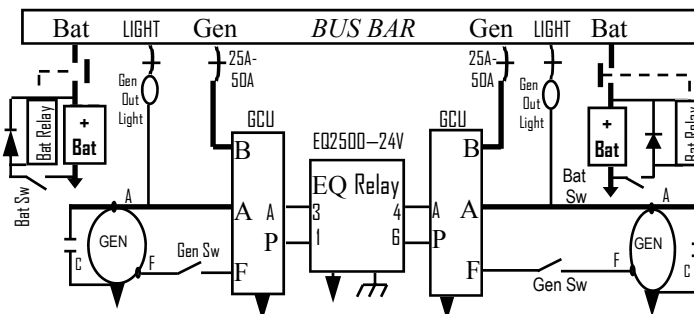

\*Some aircraft do not have GEN warning light