



G1XXKN GENERATOR CONTROLLER

V REGULATOR, REVERSE CURRENT, CURRENT LIMIT, PARALLEL (EQ)

FOR TYPE A 12V, 35 & 50 AMP DELCO-REMY GENERATOR SYSTEMS

Features:

- Voltage Regulation, IC Sense Referenced
- Electronic Controlled Generator Build-up
- Electronics Field Controller/Switching
- Current Limit, IC Sensed & Controlled
- Reverse Current Protection
- Paralleling (Equalizing, EQ or Load Sharing)
- GCU induced Over Voltage (OV) Protected
- Trouble-Shooting Lights on Unit

Benefits:

- * Increase Regulator Life. Not Temperature Sensitive
- * Prevents Regulator cycling at low RPM
- * Increase Regulator Life & Eliminate Regulator Noise
- * More Precise Current Limit
- * Prevents Battery Current Flowing to the Generator
- * Makes Generators Share Load, not over-working one
- * GCU will not cause OV fault in the system
- * Reduce Trouble-Shooting Time

Voltage Regulation: 14.2V \pm 0.4V. Max Field Current: 3A.

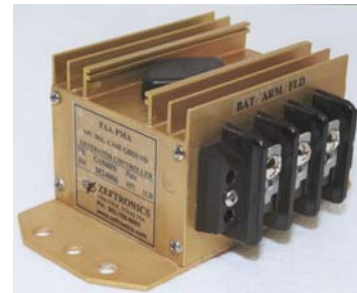
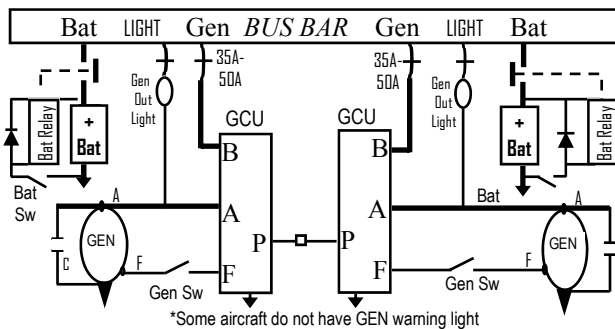

The Generator provides power used in charging the battery and running other electrical systems in the aircraft. The current flowing through the field of a Generator controls its output current. The **Generator Control Units (GCU)** have **Voltage Regulation with Generator Build-up, Current Limiter, Reverse Current Protection and Paralleling (EQ, Load sharing)**.

The **Generator Build-up** function allows the rotating generator to build-up its output from a low residual voltage to the system's voltage regulation point.

The **Voltage Regulator (VR)** controls the Generator's field to keep the aircraft electrical system voltage at a specific level. This controller has a "Type A" regulator which excites the field of the generator by providing controlled ground to one side of the field (F), with the other side internally connected to the armature.

The **Parallel or EQ function** allows two generators used on twin engine aircraft to share electrical loads equally between them via the EQ circuit.

Part No	Volt	Amp	Replaces Delco-Remy P/N
G135KN	14	35	1119145, 1119145E
G150KN	14	50	1119246, 1119246E

The **Current Limiter (CL)** controls the maximum output current the generator can produce. It turns off the field excitation when the output current exceeds the CL set point (determined by the generator's current rating). It allows normal field excitation when the generator output is below the GCU CL set point.

The **Reverse Current (RC) Protection** circuit blocks the battery current from going back to the generator. It allows current to flow only from the generator to the battery and system.

The GCU's design will cause the field current path (between the field and ground) to open if the field control device becomes internally ground shorted. This means that the GCU will not induce Over-Voltage (OV) problems into the system. The GCU does not protect the system against externally induced OV faults.



G1XXKN

GENERATOR CONTROLLER: HOW THE SYSTEM WORKS

The Generator provides power used in charging the battery and running other electrical systems in the aircraft. The current flowing through the field of a Generator controls its output current. The **Generator Control Units (GCU)** have **Voltage Regulation with Generator Build-up, Current Limiter, Reverse Current Protection and Paralleling (EQ, Load sharing)**.

The **Generator Build-up** (or automatic field flashing) function allows the rotating generator to build-up its output from a low residual voltage to the voltage regulation point. Closing the Gen (Field) switch when the generator is rotating causes current to flow from its armature through the field to ground in the GCU. This current flow rapidly increases the generator output voltage from a few volts until the build-up cut off occurs and the voltage regulator takes over the control of the generator. At the build-up cut off point, the GB switch inside the GCU opens and stays open until the Gen Field switch and Bat switches are reset. This prevents generator cycling problems seen in other voltage regulators.

The **Voltage Regulator (VR)** controls the Generator's field to keep the aircraft electrical system voltage at a specific level. This controller has a "Type A" regulator which excites the field of the generator by controlling the grounding of one side of the field (F), while the other side is internally connected to the armature. The VR electronics switch turns the field current on/off so fast (several times a second) that the output voltage of the generator stays at the VR set point. As long as the generator's output voltage is less than the VR set point the switch is closed, current flows, and the Generator's output increases. When the generator's output voltage exceeds the VR set point, the switch opens, current flow stops, and the generator's output decreases. The Current Limiter and Parallel functions affects voltage regulation.

The **Current Limiter (CL)** controls the maximum output current the generator can produce. It turns off the field excitation when the output current exceeds the CL set point (determined by the generator's current rating). It allows normal field excitation when the generator output is below the GCU CL set point.

The **Reverse Current (RC) Protection** circuit blocks the battery current from going back to the generator. It allows current to flow only from the generator to the battery and system.

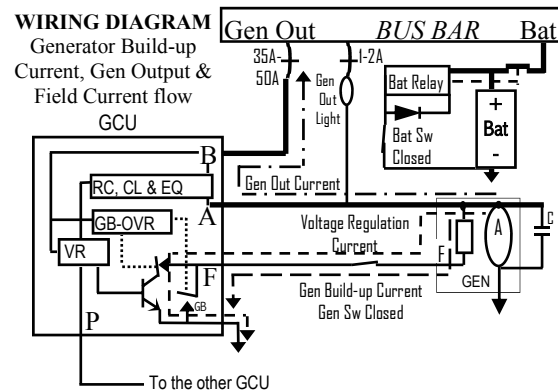

The **Equalizer (EQ) or Parallel circuit is an electronic circuit** used on twin engine aircraft to share electrical loads equally between two generator systems. It monitors and compares the output current of the two generators and automatically adjusts the voltage regulator to cause the generators to share loads equally.

Protection against GCU induced OV fault. The GCU's design will cause the field current path (between the field and ground) to open and the VR to switch off if the field control device becomes internally ground shorted. This means that the GCU will not induce Over-Voltage (OV) problems into the system. The GCU does not protect the system against externally induced OV faults. The ZEFTRONICS G1XXPN GCUs provide this prescribed OV protection.

Caution: Check the condition of the battery. A depleted /discharged battery will draw excessive current and could trigger the Current Limiter function to turn off the GCU's voltage regulator. Connecting power to the GEN field to excite it will reverse its polarity. **DO NOT connect power to the field of the generator.** Follow the Field flashing procedure outline in the trouble-shooting section of this document.



G1XXKN

GENERATOR CONTROLLER: TROUBLE-SHOOTING THE SYSTEM

CHECKING THE RESIDUAL VOLTAGE AND POLARITY OF THE GENERATOR

Connect a voltmeter between the generator's ARM and ground. At 1300 RPM, the generator's output or residual voltage should be positive (greater than +1.6V).

Residual Voltage _____ V @ _____ RPM

A negative voltage reading indicates a generator that has a reverse polarity. **Do not connect the GCU to a generator with reversed polarity. Turn off the engine and Polarize the generator by flashing the field.**

HOW TO FLASH THE GENERATOR'S FIELD:

1. With the engine off, disconnect the Generator Controller (GCU) / Regulator
2. Ground the Field wire removed from the GCU and turn on the GEN FLD switch

At the GCU: Touch the battery wire to the generator's armature wire 5 times for 3-5 seconds. Caution: Take safety precaution to prevent being hurt by electrical sparks generate by touching the two wires.

3. Connect a voltmeter between the generator's ARM and ground. At 1300 RPM, the generator output or residual voltage should be >+1.6V.
ARM Voltage _____ V @ _____ RPM

Refer to the Trouble-Shooting Diagram

1. Disconnect the GCU & EQ Relay from the system.
2. On the wires removed from the GCU & EQ relay, with the field switch open, measure the resistances at the points indicated by Ω. Record the values.

At the Generator Measured	Typical Value
ARM to GND _____ Ω	0.1Ω (Max)
FLD to ARM _____ Ω	7-10Ω
FLD to GND _____ Ω	7-10Ω

At the GCU Measured	Typical Value
ARM to BAT _____ Ω	>250Ω
ARM to GND _____ Ω	>2KΩ
FLD to ARM _____ Ω	>2KΩ
FLD to GND _____ Ω	1Ω (Max)

BUS to B _____ Ω 0.1Ω (Max)

If all the measurements are as specified, connect the GCU to the system and retest the Generator Electrical Charging System (GECS).

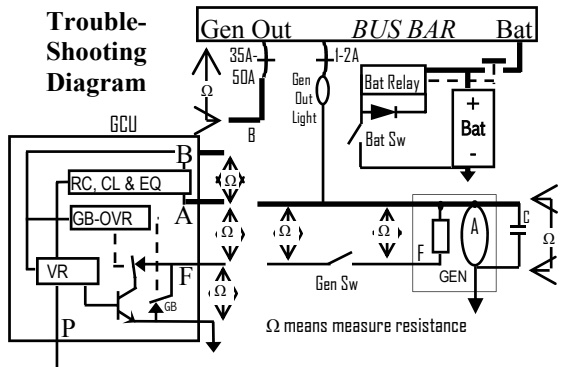
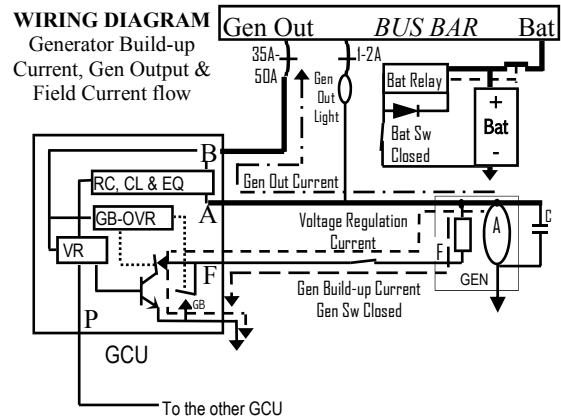

No voltage regulation or Generator not Coming on-line

With the Bat & Field switches on, engine off,

- Measure Battery voltage on the GCU BAT terminal, 0-2V on the FLD, and 0 volt on the ARM terminal.
- If the measured values are as specified, perform the resistance measurements called for on this page (TROUBLE-SHOOTING THE SYSTEM).
- If the generator is coming on line after 1400 RPM, remember that *some Generator overhaul shops use armature windings with excessively high resistance. A high Armature resistance will cause the generator to come on-line at engine speeds above 1400 RPM. A 50A generator with ARM to GND resistance of 0.4Ω may not come on line until the generator's residual voltage overcomes that internal resistance at a higher speed. That is just Ohm's law.*



Installation & Continued Airworthiness Maintenance Instructions

GENERATOR CONTROLLER: TROUBLE-SHOOTING THE SYSTEM

CAUTION:

Grounding the field to see if the generator produces current is not a good indication that it is working properly. Doing so can lead to excessive system voltage, which may damage batteries, radios and GCU. This practice will not always identify a defective voltage regulator because it can and does often hide field or armature defects.

PRE-INSTALLATION TESTS.

BEFORE INSTALLING THIS UNIT, PERFORM TESTS:

1. Read the documents that came with the unit.
2. Disconnect the current voltage regulator or GCU.
3. Charge Gell-cell batteries before installing the unit.
4. Turn on the Gen Field switch
5. Check the Generator Residual Voltage & Polarity:
 - a. Connect a voltmeter between the Generator's ARM and ground.
 - b. At 1200 RPM, the generator's output should be positive (>1.6V). If it is negative, the generator has a reverse polarity. Turn off the engine, and flash the field. Do NOT connect the GCU to the generator.
6. Measure and record the following resistances separately, at the generator & the wires to the GCU, list them below.

	At Generator	At GCU Wire
a. Gen Arm to Case-Ground	_____Ω	_____Ω
b. Gen Fld to Case-Ground	_____Ω	_____Ω
c. Gen Fld to ARM	_____Ω	_____Ω
d. Bus-GCU BAT	_____Ω	_____Ω
7. If the measured values are out of the specified ranges (listed on page 3), check the wiring, circuit breakers, switches, connection or generator.
8. If the measured values are as specified, install the unit and perform the post installation tests.

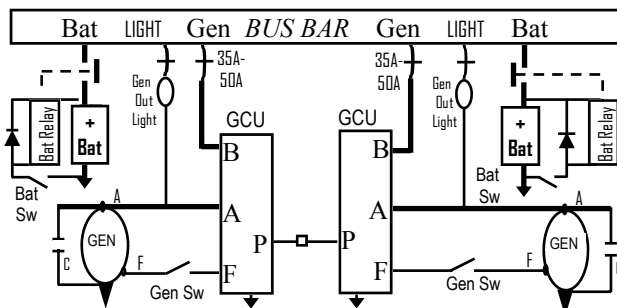

OUR GOAL IS TO HELP YOUR SYSTEM OPERATE BETTER AND HELP YOU BETTER UNDERSTAND ITS OPERATION.

INSTALLATION INSTRUCTION & TESTS.

1. Mount the GCU in place of the removed regulator.
2. Connect the ARM, FLD, BAT and P to the GCU.
3. With the engine off, turn on the Bat & Gen Field switches; on the GCU measure & record the following voltage:

	12V Values	Typical Values
A. BAT	_____V	11 – 13V
B. FLD	_____V	0 – 2.5V
C. ARM	_____V	0 – 0.2V
D. P (EQ)	_____V	>3.9-6.5V*

*Depending on the battery voltage, may be lower than 3.9V

4. If the measured values are as specified, connect the unit and perform the post installation tests.

POST-INSTALLATION CHECK AND TESTS

1. With the BAT and FLD switches on and engine off, on the GCU the GO (Gen Out*), VR (Voltage Regulator), and CL (Current Limit) lights should be on. If the CL light is OFF remove the GCU and check the generator for correct polarity and wiring.
2. With the BAT and FLD switches on and engine running, the generator should come on line at 1100 - 1400 RPM: the bus voltage should be 13.8V to 14.4V. At 1800 RPM the bus voltage should remain at 13.8V to 14.4V until about 5 Amps below the generator's current rating

**On units that have serial numbers starting with M or N, the GO light may be off until the bus voltage exceeds 12.3V-13.3V. On units with serial numbers starting with P, the GO light will come on only when the GEN voltage is less than bus voltage.*

*For tech help, tech cards and system design assistance, call: 903-758-6661.
Fax: 903-236-9766*

INSTRUCTIONS FOR

CONTINUED AIRWORTHINESS MAINTENANCE

This device is not field repairable or serviceable. For all service, repair or overhaul needs, return it to ZEFTRONICS or a ZEFTRONICS approved repair station. For all periodic inspection and test requirement, use the pre and post installation procedure listed above.