



# V2510A

## 32V ELECTRONIC OVER VOLTAGE RELAY

### FOR TYPE A OR TYPE B 28V VOLTAGE REGULATORS



#### Features:

- Over-Voltage Protection
- Counter-EMF protected Relay
- Integrated Circuit OV sensor
- Versatile Applications

#### Benefits:

- \* Protects system against overexcited alternator field
- \* Increase the life of the OV Relay
- \* Less temperature sensitive and more precise.
- \* Works in Types A, B, C & other system configurations

Over Voltage Protection: 32.0V ± 0.8V. Max Field Current: 5A.

#### OVER VOLTAGE (OV) PROTECTION

The OV Protector (OVP) or OV Relay deactivates the Voltage Regulator by removing power to its input if the bus voltage exceeds 32V. This removes excitation from the alternator and thus protect sensitive avionics equipment and the battery.

#### VOLTAGE REGULATION

Using the voltage sensed from the OV Relay output, the Voltage Regulator keeps the bus voltage constant by controlling the alternator's field current: increasing it when the system load increases and decreasing it when the load drops.

#### Type A Voltage Regulation:

A "Type A" regulator excites the field of the alternator by providing controlled ground to one side of the alternator field (F2), with the other side (F1) powered by the OVR output.

#### Type B Voltage Regulation:

A "Type B" regulator excites the field of the alternator by providing controlled power to one side of the alternator field (F2), with the other side (F1) is grounded.

#### Type C Voltage Regulation (not shown here):

A "Type C" regulator is similar to the "Type A" in that it excites the field of the alternator by providing controlled ground to one side of the alternator field (F2), with the other side (F1) powered by the alternator's (BAT) output. In this application, the OVR connection is different.

#### Wiring Diagram

Type A: VR/ACU provides controlled ground to one side of the alternator field

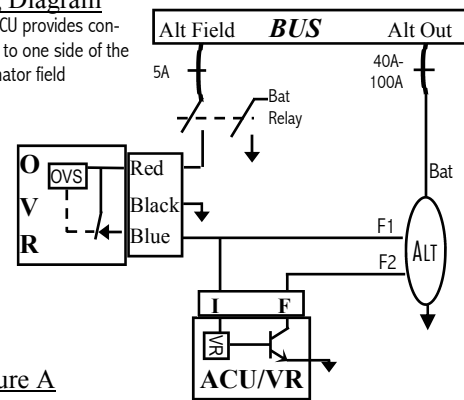

Figure A

#### Wiring Diagram

Type B: VR/ACU provides controlled Power to one side of the alternator field

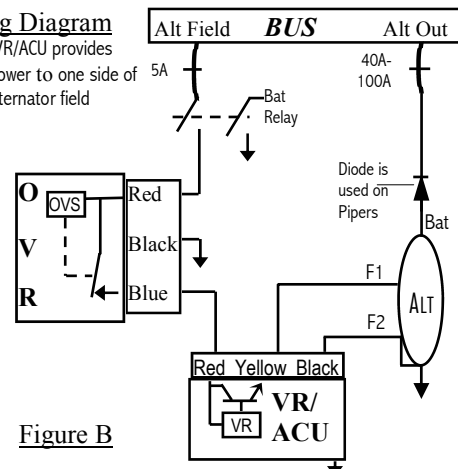

Figure B

The V2510A replaces

- PIPER: 484-182
- PFT/LAMAR: B00266
- PRESTOLITE: FOC 4003A



# V2510A

## 32V ELECTRONIC OVER VOLTAGE RELAY FOR TYPE A OR TYPE B 28V VOLTAGE REGULATORS

### HOW THE SYSTEM WORKS

Turning on the master switch applies battery voltage to the input of the Alternator Controller or Voltage Regulator (VR) through the Over-Voltage Relay (OVR).

In the "Type A" charging system configuration, the VR applies controlled grounding to one side of the alternator's field while the other side has power on it from the OVR. Without the engine running, the field voltage is typically 0-2V. With the engine running, 26-0.5V while the bus voltage is at 28V. The field voltage starts out high and decreases with increased system load. If the field voltage becomes 0, the system will experience an OV condition, and the OV Relay will open to turn off the VR thereby removing excitation from the alternator's field.

In the "Type B" charging system configuration, the VR applies controlled power to the field of the alternator. Without the engine running, the field voltage is typically 0.5-2V less than the bus or battery voltage. For example, if the bus voltage is 25V, the field voltage is typically 22.0 to 23.5V. With the engine running, it is typically 0.5-26V while the bus voltage is at 28V. The field voltage starts out low and increases with increased system load. If the field voltage becomes the same as the bus voltage, the system will experience an OV condition, and the OV Relay will open to turn off the VR thereby removing excitation from the alternator's field.

### Over Voltage Protection

The OV Relay is a normally closed switch which opens when the bus voltage exceeds 32V. It has a time delay that prevents nuisance tripping caused by system noise or voltage spikes.

The regulated bus voltage is normally about 28V unless the alternator is self-current limiting<sup>1</sup> or if there is voltage drop in the alternator field circuit breaker, alternator switch, OV Relay, or wiring and connections between the bus and the red wire on the VR. These voltage drops across the different components and connections occur when current, (up-to 3 Amps in some instances), passes through the resistance built-up in them. *The resistance build-up causes flickering ammeter and instrument panel lights.*

<sup>1</sup> self-current limiting—Internal characteristics of the alternator that causes it to limit its current and voltage output at a given speed.

### INSTALLATION INSTRUCTION

1. Disconnect and remove the present ACU/VR.
2. At the ACU/VR, measure the alternator's field resistance: i.e. resistance between the field and the ground wire. A resistance of 10 to 18Ω is normal. If the measured resistance is outside the specified range, check the alternator field and the connections/wire from the alternator's field wire (at the ACU/VR) to ground for "Type B" configuration and field wire to the OVR output wire for "Type A". 0Ω indicates a field to ground short. Correct fault found.
3. Verify that the input (Alt Switch, Field breaker, etc) resistance to the OVR is below 0.1Ω. Correct faults found.
4. Mount the OVR and connect the OVR and ACU/VR to the system.
5. Perform the Post Installation Test Procedure.

### POST INSTALLATION TEST PROCEDURE

1. Turn on the Master switch and measure
  - Bus voltage \_\_\_\_\_ V.
  - OVR Red wire (input) voltage \_\_\_\_\_ V
  - OVR Blue wire (output) voltage \_\_\_\_\_ V
  - VR Red wire (input) voltage \_\_\_\_\_ V
  - VR Blue wire (output) voltage \_\_\_\_\_ V

The inputs should read bus voltage. VR output voltage on the "type A" should read 0-2V, and on the "type B", 0.5-2V less than the bus voltage.
2. If the step 1 is successful, perform step 3.
3. Turn Off all the avionics. Start the engine. At 1500-1600 RPM measure bus voltage: It should read 27.5V - 28.4V. If the bus voltage exceed these limits, check for voltage drop in the 5A breaker, the Alt switch, and pre-ACU/VR wires.

### TROUBLE-SHOOTING THE SYSTEM

See the Trouble-Shooting Notes (TSN) page and or TECHCARDS for information on how to solve problems in the system.

### WIRING DIAGRAMS

See page 1 for wiring diagrams of the "type A" and "type B" configurations.



### TROUBLE-SHOOTING THE SYSTEM

## 28V Type B alternator system on Piper, Beech, etc V2510A or other OV Relays

When the master switch (ALT & BAT) is turned on, battery voltage is applied to the Bus & OV Relay input.

Take all voltage measurements at test points (TP) A, D, E and F referenced to ground.

- |                        |                        |
|------------------------|------------------------|
| A. _____ Volts.        | D. _____ Volts         |
| E. _____ Volts. VR     | E. _____ Volts. OVR    |
| F. _____ Volts. Type A | F. _____ Volts. Type B |
| F1 _____ Volts. Type A | F2 _____ Volts. Type A |
| F1 _____ Volts. Type B | F2 _____ Volts. Type B |

The voltages measured at points A, D, and E should be Bus voltage (about 24V).

For the “type A” of figure A, the voltage on F & F2 will be 0 to 2V. The voltage at F1 & E will be the same.

For the “type B” of figure B, the voltage on F & F1 will be 0.5 to 2V less than the voltage at A, D, or E.

*If the voltage at A is 0.2V more than that on E, check the 5 Amp breaker, ALT switch, and connections between the bus and E for high resistance or open circuit. A high resistance between A & E may lead to flickering / oscillating ammeter and panel lights. An open circuit between A & E will not allow current to get to the VR and subsequently no current to the alternator’s field and no voltage regulation. When there is no voltage regulation, the Bus voltage remains at battery voltage (about 12V).*

*For figure A, if the voltage on F2 is close to the voltage on E or F1, check for poor connection or open circuit between the VR (F) and F2 on the alternator (ALT) or open field in the ALT.*

*If the F1 voltage is close to 0, check for a ground short on F1 in the ALT or wire from E.*

*For figure B, if the voltage on F1 is more than 0.2V above the F voltage, check for poor connection or open circuit between the VR output and F1 on the alternator.*

*If the voltage on F1 is close to 0, check for a ground short on F1 on the alternator or wire from F on the VR.*

*If the resistance between the F and F1 is higher than 1Ω, the alternator may not carry its rated load, showing a symptom similar one where there is an open stator wire or open diode in the alternator.*

*An open stator wire or open diode in the alternator will make the alternator only able to carry about half its rated output. For example, a 70A 24V alternator has a 28V output with about 30A load on it.*

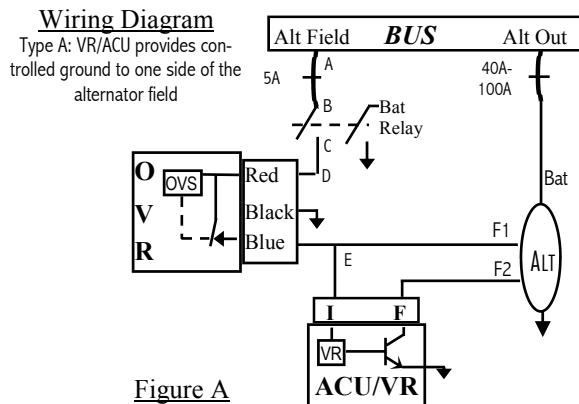

Figure A

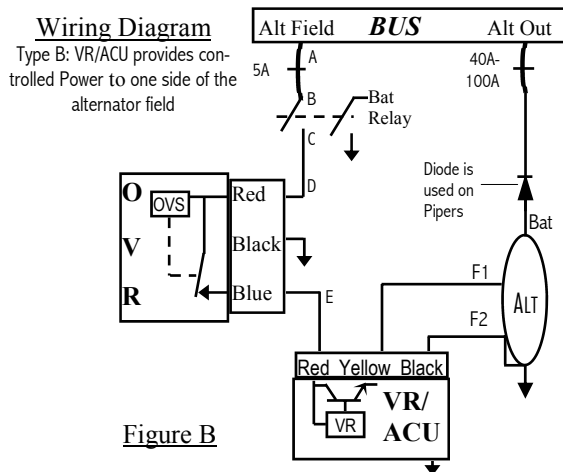

Figure B

... trouble-shooting continued

*When the load is increased to 40A, the bus voltage drops to 25 to 27V, indicating an alternator that is current limiting.*

See [TechCard](#) for resistance and voltage measurements.

#### For type A systems:

The R25V0N combines the VR & OVR with OV and Low Voltage Indicator.

For type B systems: The A2540M combines the VR & OVR with OV Indicator.

For type B systems: The R2530L combines the VR & OVR with OV and Low Voltage Indicator.



## Frequently Asked Questions & TECHCARD Notes

### 28V Type B alternator system on Piper, Beech, etc

### *TROUBLE-SHOOTING THE SYSTEM*

#### Flickering / oscillating ammeter and panel lights.

Check the components and connections between A and D for high resistance or intermittent connection.

#### No voltage regulation

With the master switch on and Battery voltage measured on the OV Relay output, look for Bus voltage on the VR input and output.

- If there is no Bus voltage on the ACU input, look for a broken wire between the ACU and the OVR.
- If the input voltage is more than 0.2V lower than the bus voltage, look for & correct the device (5A breaker, ALT switch, OVR or connection or wire) that is causing it.
- If the output voltage is 0 and the input has battery voltage, look for a grounded alternator field or field wire. If the field resistance is correct as shown in step 5 of the installation tests send the VR in for test/repair.
- If it is internally shorted, repair the field ground fault or replace the alternator.
- If the output voltage is the same as the input voltage, look for an open alternator field or field wire. If the field resistance is higher than what is shown in step 5 of the installation tests, send the alternator in for test/repair. If the field resistance is correct, send the VR in for test/repair.

#### Bus voltage remains at battery voltage (about 24V)

To solve this problem, see [No voltage regulation](#).

#### Alternator carries only about half its rated output.

Look for an open stator wire or open diode in the alternator. In Piper PA 31 & 60 series, check the condition of the diode between the bus and alternator output. Check the shunts and alternator output wires, indicating an alternator that is current limiting.

#### Bus voltage drops with load increase

For a solution, see [Alternator carries only about half its rated output](#).

#### Wiring Diagram

Type A: VR/ACU provides controlled ground to one side of the alternator field

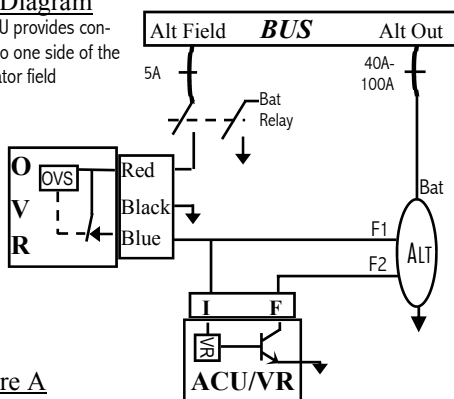

Figure A

OUR GOAL IS TO HELP YOUR SYSTEM OPERATE BETTER  
AND HELP YOU BETTER UNDERSTAND ITS OPERATION.

ZEFTRONICS  
TECHCARDS

**INSTALLATION TESTS.** BEFORE INSTALLING THIS UNIT, PERFORM TESTS:

1. Read pages 1 to 3 and this page.
2. Check for and replace open, frayed, or broken wires. Clean thoroughly or replace corroded, dirty, or oxidized connections, terminals, contact, or poorly soldered wire junction.
3. Check for Open or Ground-shortened alternator field. Most 24V alternators have 10-18Ω field resistance. Ground shorted alternator field will damage most Voltage Regulators/ACU. **If the alternator has a field to ground short, do not connect the ACU/Regulator to it.**
4. With the engine off: Check voltage drops across the field and Alt circuit breakers, and OV relay. High voltage-drop means excessive junction resistance and will lead to many problems like: fluctuation ammeters, charge-meters and panel lights.
5. Perform and record the following tests with the **Master Switch Off:**

	24V Values	Typical Values
A. Field resistance at ALT	_____ Ω	10 – 18Ω
B. Field resistance at ACU	_____ Ω	10 – 18Ω
C. Field SW resistance	_____ Ω	0 – 0.1Ω
D. Field C/BKR resistance	_____ Ω	0 – 0.05Ω
E. ALT C/BKR resistance	_____ Ω	0 – 0.05Ω
6. Perform and record the following tests with the **Master Switch On:**

	24V Values	Typical Values
F. BUS Volt Engine Off	_____ V	24 – 26V
G. ACU/Reg input Volt	_____ V	24 – 26V
H. Field Voltage, type B	_____ V	0.5-2V <Vbus
I. Field Voltage, type A	_____ V	0.5-2V
7. **Post Installation.** If all tests are correct to or per steps 5 & 6, run the engine and record:

	24V System	Typical value
J. Bus voltage	_____ V	27.4 – 28.4V

For tech help & other TechCards, call:

**903-758-6661**

©ZEFTRONICS, 2002

**ZEFTRONICS**  
Electrical Charging System Solutions

#### Wiring Diagram

Type B: VR/ACU provides controlled Power to one side of the alternator field

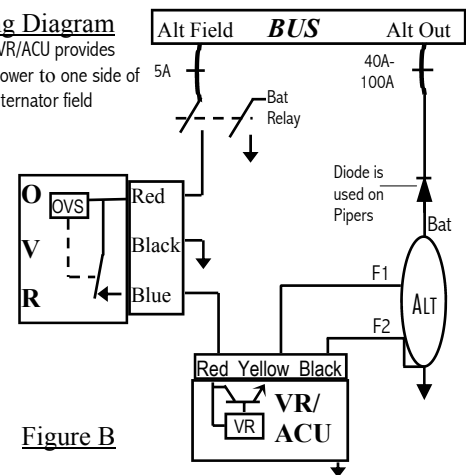

Figure B