



TROUBLE-SHOOTING TYPE A 12 TO 50 AMP DELCO-REMY SINGLE ENGINE GENERATOR SYSTEMS: HOW THE SYSTEM WORKS

By: Femi G. Ibitayo

The Generator provides power used in charging the battery and running other electrical systems in the aircraft. The current flowing through the field of a Generator controls its output current. The **Generator Control Units (GCU)** have **Voltage Regulation with Generator Build-up, Current Limiter, and Reverse Current Protection**.

The **Generator Build-up** (or automatic field flashing) function allows the rotating generator to build-up its output from a low residual voltage to the system's voltage regulation point. Closing the Gen (Field) switch when the generator is rotating causes current to flow from its armature through the field to ground in the GCU. This current flow rapidly increases the generator output voltage from a few volts until the build-up cut off occurs and the voltage regulator takes over the control of the generator. At the build-up cut off point, the GB switch inside the GCU opens and stays open until the Gen Field switch and Bat switches are reset. This prevents generator cycling problems seen in other voltage regulators.

The **Voltage Regulator (VR)** controls the Generator's field to keep the aircraft electrical system voltage at a specific level. This controller has a "Type A" regulator which excites the field of the generator by controlling the grounding of one side of the field (F), while the other side is internally connected to the armature. The VR electronics switch turns the field current on/off so fast (several times a second) that the output voltage of the generator stays at the VR set point. As long as the generator's output voltage is less than the VR set point the switch is closed, current flows, and the Generator's output increases. When the generator's output voltage exceeds the VR set point, the switch opens, current flow stops, and the generator's output decreases.

The **Current Limiter (CL)** controls the maximum output current the generator can produce. It turns off the field excitation when the output current exceeds the CL set point (determined by the generator's current rating). It allows normal field excitation when the generator's output is below the GCU CL set point.

The **Reverse Current (RC) Protection** circuit blocks the battery current from going back to the generator. It allows current to flow only from the generator to the battery and system.

This document assumes that the user has a Zeftronics Electronics GCU in the system and so approaches trouble-shooting and the operation of the system from that point of view. The operation of the vibrating point Regulators are similar, so the reader may adapt these notes to their system. We do not guarantee the results. These notes are for information purposes only.

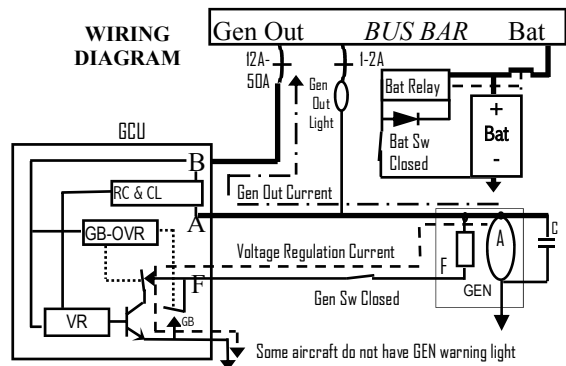
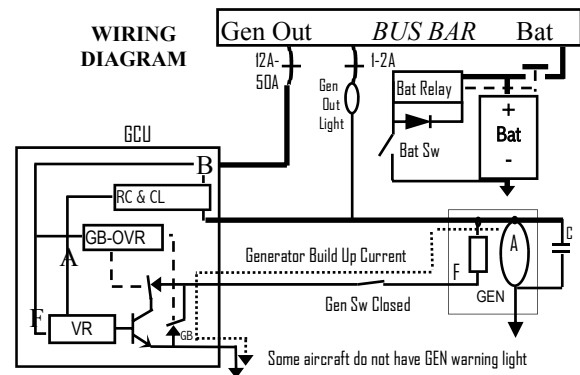

Caution: Check the condition of the battery. A depleted /discharged battery will draw excessive current and could trigger the Current Limiter function to turn off the GCU's voltage regulator.

Connecting power to the GEN field to excite it will reverse its polarity. **DO NOT connect power to the field of the generator.** Follow the Field flashing procedure outline in the trouble-shooting section of this document.



TROUBLE-SHOOTING TYPE A 12 TO 50 AMP DELCO-REMY SINGLE ENGINE GENERATOR SYSTEMS

By: Femi G. Ibitayo

CHECKING THE RESIDUAL VOLTAGE AND POLARITY OF THE GENERATOR

Connect a voltmeter between the generator's ARM and ground. At 1300 RPM, the generator output or residual voltage should be positive (greater than +1.6V).

Residual Voltage _____ V @ _____ RPM

A negative voltage reading indicates a generator that has a reverse polarity. **Do not connect the GCU to a generator with reversed polarity.**

Turn off the engine and Polarize the generator by flashing the field.

HOW TO FLASH THE GENERATOR'S FIELD:

1. With the engine off, disconnect the Generator Controller (GCU) / Regulator
2. Ground the Field wire removed from the GCU and turn on the GEN FLD switch

At the GCU: Touch the battery wire to the generator's armature wire 5 times for 3-5 seconds. Caution: Take safety precaution to prevent being hurt by electrical sparks generated by touching the two wires.

3. Connect a voltmeter between the generator's ARM and ground. At 1300 RPM, the generator output or residual voltage should be >+1.6V.
ARM Voltage _____ V @ _____ RPM

Refer to the Trouble-Shooting Diagram

1. Disconnect the GCU from the system.
2. On the wires removed from the GCU, with the field switch on measure the resistances at the points indicated by Ω. Record the values.

At the Generator Measured	Typical Value
ARM to GND _____ Ω	0.1Ω (Max)
FLD to ARM _____ Ω	7-10Ω
FLD to GND _____ Ω	7-10Ω

At the GCU Measured	Typical Value
ARM to BAT _____ Ω	>250Ω
ARM to GND _____ Ω	>2KΩ
FLD to ARM _____ Ω	>2KΩ
FLD to GND _____ Ω	1Ω (Max)
BUS to B _____ Ω	0.1Ω (Max)

If all the measurements are as specified, connect the GCU to the system and retest the Generator Electrical Charging System (GECS).

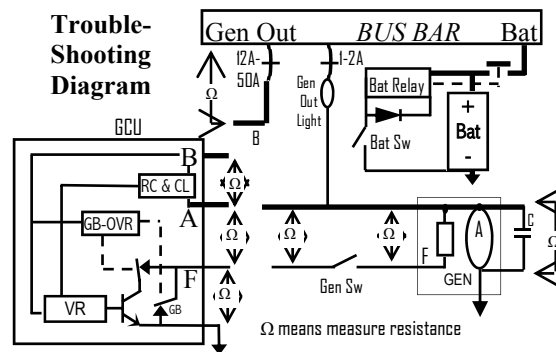
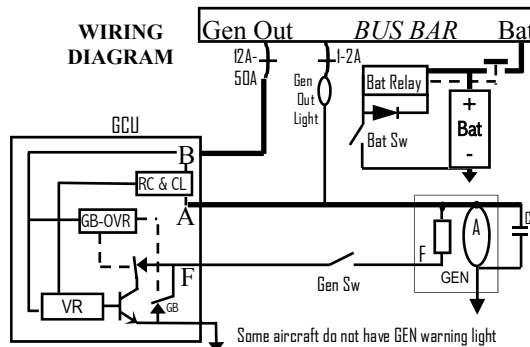

No voltage regulation or Generator not Coming on-line

With the Bat & Field switches on, engine off,

- Measure Battery voltage on the GCU BAT terminal, 0-2V on the FLD, and 0 volt on the ARM terminal.
- If the measured values are as specified, perform the resistance measurements called for on this page (TROUBLE-SHOOTING THE SYSTEM).
- If the generator is coming on line after 1400 RPM, remember that *some Generator overhaul shops use armature windings with excessively high resistance. A high Armature resistance will cause the generator to come on-line at engine speed above 1400 RPM. A 50A generator with ARM to GND resistance of 0.4Ω may not come on line until the generator's residual voltage overcomes that internal resistance at a higher speed. That is just Ohm's law.*